

Evaporator					
Dew		Dew		Dew	
(F)	(psig)	(F)	(psig)	(F)	(psig)
-44	0.5	-14	17.3	16	45.9
-42	1.3	-12	18.8	18	48.3
-40	2.2	-10	20.4	20	50.8
-38	3.1	-8	22.0	22	53.4
-36	4.0	-6	23.7	24	56.0
-34	5.0	-4	25.4	26	58.8
-32	6.1	-2	27.1	28	61.6
-30	7.1	0	29.0	30	64.4
-28	8.3	2	30.9	32	67.4
-26	9.4	4	32.8	34	70.4
-24	10.6	6	34.8	36	73.6
-22	11.9	8	36.9	38	76.8
-20	13.2	10	39.1	40	80.1
-18	14.5	12	41.3		
-16	15.9	14	43.6		

Bubble					
Bubble		Bubble		Bubble	
(F)	(psig)	(F)	(psig)	(F)	(psig)
80	174.7	102	242.7	122	319.2
82	180.3	104	249.7	124	327.7
84	185.9	106	256.8	126	336.3
86	191.7	108	264.1	128	345.1
88	197.7	110	271.5	130	354.1
90	203.7	112	279.1	132	363.3
92	209.9	114	286.8	134	372.7
94	216.2	116	294.6	136	382.2
96	222.6	118	302.7	138	391.9
98	229.2	120	310.8	140	401.8
100	235.9				

REMEMBER

WHEN CONVERTING OR RETROFITTING

DID YOU.....?

- ✓ Verify your low pressure control, evaporator or crankcase pressure regulator to the corresponding P/T relationship.
- ✓ Confirm the fan cycling setpoints.
- ✓ Label the system.
- ✓ Verify the metering device sizing.

Unless the service conditions indicate contamination, oil change is not required and standard filter driers can be used. Remember oil loss can occur during the recovery process. Check oil level after system has stabilized. Adjust if necessary.

If leaks occur, you may recharge (top-off) without effecting system performance.

As with other replacements, systems directly converted from CFC's and HCFH's to HFC's may experience shrinkage of o-rings or gaskets, which could contribute to leakage.

Use of One Shot(C) in R-502, R-422A, R-408A, R-404A, R-402A, R-402B and R-507A conversions may not require an expansion valve replacement. As with R-404A and R-507A, the use of One Shot in R-22 retrofits will have a minimum requirement of an element change, but may require a valve replacement.

CONTACT YOUR DISTRIBUTOR FOR ASSISTANCE IN VALVE SELECTION

If there are any questions concerning the application of One Shot(C), contact ICOR's TECH2TECH service at 866-433-8324 or go to www.icorinternational.com.

ONE SHOT®(C) IS ANOTHER QUALITY PRODUCT FROM THE PRODUCERS OF HOT SHOT® and NU-22B® LEADING THE INDUSTRY IN REPLACEMENT REFRIGERANTS

ISO 9001:2000
REGISTERED

10640 E. 59th Street • Indianapolis, IN 46236
800-497-6805 • Fax 317-826-3214
icorinfo@icorinternational.com • www.icorinternational.com

CONVERSION GUIDELINES



R-422C

ONE SHOT®(C)

- ✓ ASHRAE DESIGNATED AND SAFETY CLASSIFIED A1: NONTOXIC AND NONFLAMMABLE
- ✓ 20% LOWER GLOBAL WARMING POTENTIAL POTENTIAL THAN R-404A AND R-507A
- ✓ COMPATIBLE WITH ALL STANDARD REFRIGERANT OILS
- ✓ ZERO OZONE DEPLETION
- ✓ EPA SNAP LISTED
- ✓ MANUFACTURED IN ACCORDANCE WITH ARI 700-95
- ✓ LOWER CONVERSION COSTS
- ✓ REPLACES R-502, R-404A, R-402A, R-402B, R-408A, R-507A, R-22 (Low & Medium Temperature Applications)
- ✓ STOCKING DISTRIBUTORS NATIONWIDE
- ✓ BACKED BY WARRANTY
- ✓ CAN BE TOPPED OFF
- ✓ IMPROVED EFFICIENCIES

Conversion Data

Pre Post

Suction P/T			
Discharge P/T			
Superheat - Evap			
-Comp			
Sub-cooling			
Ambient Temp			
Weight of Refrigerant			
Oil - Temp			
- Levels			
Comp Amps			
L1		L2	
			L3
Starting Charge Percentage (%)			
Verify Superheat and Subcooling			
R502	95	R404A	110
R22	97	R408A	108
R402A	100	R507A	109
R402B	100	R422A	100

TECH2TECH
REFRIGERANT RELATED
DIAGNOSTIC SUPPORT
866-433-TECH (8324)

ICOR
INTERNATIONAL
"making your life easier™"

Change from CFC and HCFC to HFC refrigerants may cause a retraction in the o-rings and elastomers. Be sure to repair or replace after recovery of the original refrigerant. Failure to address this at this time may cause unnecessary loss of refrigerant.

ICOR recommends verification of the metering device sizing with the distributor or manufacturer of the device.

1) RECORD SYSTEM PRE-CONVERSION DATA: Prior to converting, the system should be monitored and all system and component operating conditions recorded for future reference. (SEE FORM ON REVERSE SIDE)

2) RECOVER THE REFRIGERANT 100% of the refrigerant must be recovered from system in accordance with all EPA guidelines.*Recording the weight of the refrigerant you recover will assist you in determining the amount of One Shot®(C) necessary for the conversion.

3) PERFORM OIL ANALYSIS: Check system oil for acidity, water and solids (metal shavings). If detected perform a complete system oil change using the OEM specified type and amount of oil.

4) INSTALL NEW FILTER DRIER AND OIL FILTER: The oil analysis will tell you what type of filter drier you need to use. Systems with coalescent oil separators and/or compressor oil filters need to be changed, too.

5) LEAK CHECK SYSTEM: Pressure test system with dry nitrogen. DO NOT exceed the equipment's design pressure. One Shot®(C) can be detected with any standard form of leak detection designed to detect HFC refrigerants.

6) EVACUATE SYSTEM: To remove non-condensables and moisture in the system, a minimum 500 micron vacuum must be achieved.

7) CHARGE SYSTEM: Remove LIQUID ONLY from One Shot®(C) cylinder. When initially charging system, One Shot®(C) can be added directly into the receiver tank or high-pressure side of the system with compressor off. Charge ratios for One Shot®(C) may vary depending on system design and application. The initial charge of One Shot®(C) should be 95% of the original existing refrigerant charge.

8) RUN SYSTEM: Check pressures, subcooling, and superheat temperatures. Use One Shot®(C) P/T chart on reverse side. If additional One Shot®(C) needs to be added, do so in 5% increments and DO NOT exceed 115% of the original charge of existing refrigerant. If system performance is inadequate, call ICOR for support at 866-433-8324.

9) PROPERLY LABEL SYSTEM: Avoid mixing refrigerants by properly labeling your system. For One Shot®(C) system ID labels, call the ICOR support hotline at 800-497-6805.

10) POSTCONVERSIONLEAKCHECK: After operation of system begins, do a thorough system leak check.

11) RECORD SYSTEM POST CONVERSION DATA: Monitor and evaluate system performance and record data. This information can be compared to your pre-conversion data for a full conversion evaluation and can be used if further technical support is required.

CONVERSION GUIDELINES

FOR R-502, R-422A, R-402A, R-402B, R-404A, R-408A, R-507A, and R-22 (medium and low temperature applications) direct expansion systems.

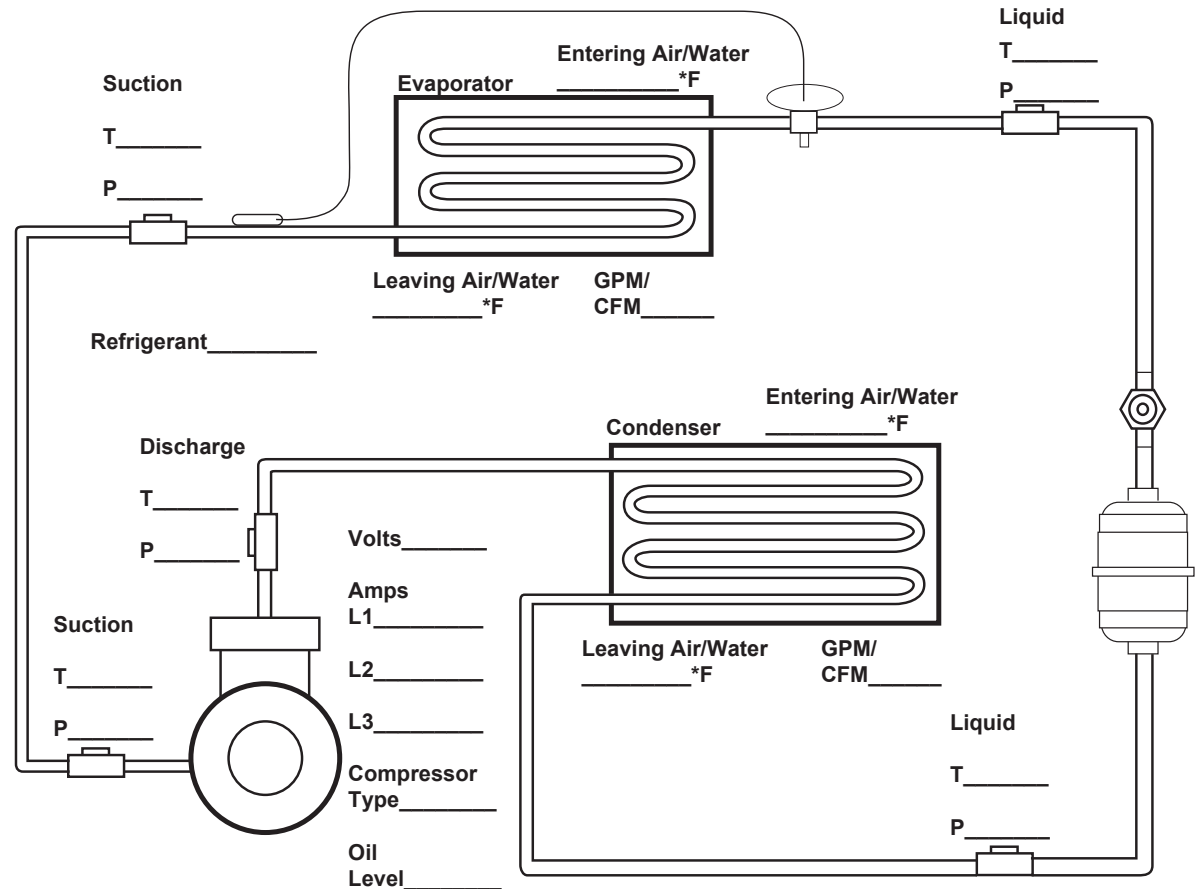

One Shot®(C) (R-422C) is a non-ozone depleting blend, which can be used as a direct refrigerant replacement into existing refrigerant systems. It is compatible with all standard ACR system lubricants, i.e. MO, AB, and POE oils.

System Requirements:

- 1) System must be designed for use with medium or low temperature refrigeration, free of leaks, and in sound operating condition.
- 2) One Shot®(C) is designed for use in systems utilizing direct expansion metering, i.e. TXV, orifice, cap tube. Before using One Shot®(C) in a flooded system, consult ICOR's technical staff.

- 3) The system should be operating within its design capacity. Conversion to One Shot®(C) may not increase system capacity. Consult ICOR before converting any system with pre-existing capacity problems.

- 4) The system should be charged with the proper type and amount of lubricant, as required by the original equipment and component manufacturers.

NOTIFICATION TO USERS: The information contained in this document is given in good faith based on our current knowledge. It is only an indication and should not be construed as an endorsement or guarantee of performance to any specific application and is in no way binding. We guarantee that our products comply with our sales specifications. This information is not to be used as a substitution for system analysis as to suitability. Users are responsible for compliance with local, state, and federal regulations for recovery and evacuation.